



## 40RBW Series

*Packed Chilled Water Air Handling Unit*  
111,180 - 883,000 BTUH



# 40RBW Series



**Only the 40RBW Series offers you**

**Versatility**

- Full line of packaged unit 10-74 tons.
- Choice of air discharge arrangements
- Free blow or with ductwork

**Adaptability**

- Ceiling suspended or floor mounted
- Attractive appearance for use in the space

**Dependable Carrier Quality**

- Efficient coil surface
- Rugged modular construction
- Quiet, belt-drive centrifugal fans

## 40RBW Series - The industry's most complete line of packaged chilled water air handling unit

Specify Carrier **40RBW Series** packaged chilled water air handling units for commercial in-the-space application in factories warehouses offices or stores if a source of chilled water is available, you can't afford to overlook the versatile packaged units of the 40RBW Series.

These attractive unit are available in 14 popular sizes. Covering 4,000-25,500 cfm. range with nominal cooling capacities from 10.3 tons.

Floor mounted or ceiling suspended. Units are real space savers. Their narrow width (less than 3-ft) makes them easy to get into existing spaces.

Cooling coils are constructed of copper tubes with mechanically corrugate fins. Offering efficient high heat transfer surface that's built with years of dependable service in mind.

The smooth finish baked enamel cabinets are fabricated of rugged. Heavy-gage galvanized steel. Belt-drive centrifugal fans move large volumes of air quietly and efficiently may be used with ductwork or for free blow (direct discharge) into the conditioned space.

Yes, if you're looking for the most in versatility and operating performance in packaged chilled water air handling units. Look to the 40RBW Series. From Carrier of course.

## Model Nomenclature

Digit no.	1	2	3	4	5	6	7	8	9	10	11	12
Model	4	0	R	B	W	0	3	0	-	3	R	H

Chilled water air handling unit, 40RBW Series

Unit size = 012, 015, 018, 021, 024, 027, 030, 033, 036, 040, 050, 060, 080

H = Horizontal Unit, V = Vertical Unit, S=Short Horizontal Unit

R = Right Hand Coil , L = Left Hand Coil

3 = 3 Rows coil, 4 = 4 Rows coil

# Physical data

Model		Packaged Chilled Water Air Handling Unit											
		40RBW											
		012-3	012-4	015-3	015-4	018-3	018-4	021-3	021-4	024-3	024-4	027-3	027-4
Nominal Capacity	Cooling Capacity *	128,200	157,470	162,710	193,190	191,450	228,950	225,650	268,010	258,320	307,410	290,490	345,470
	Air Flowrate **	4,000	4,000	5,100	5,100	6,000	6,000	7,000	7,000	8,000	8,000	9,000	9,000
Operating Weight		210	220	270	280	270	290	380	400	390	410	400	420
	Coil Arrangement	3/14	4/14	3/14	4/14	3/14	4/14	3/14	4/14	3/14	4/14	3/14	4/14
Coil	Coil Face Area	8.19	8.19	10.51	10.51	12.33	12.33	14.49	14.49	16.49	16.49	18.49	18.49
	Coil / Fin Material	Cu/Al	Cu/Al	Cu/Al	Cu/Al	Cu/Al	Cu/Al	Cu/Al	Cu/Al	Cu/Al	Cu/Al	Cu/Al	Cu/Al
Fan	No. of circuit	1	1	1	1	1	1	1	1	1	1	1	1
	Fan Size	10"x10"	12"x12"	12"x12"	12"x12"	12"x12"	12"x12"	15"x15"	15"x15"	15"x15"	15"x15"	15"x15"	15"x15"
Motor	Fan Qty	2	2	2	2	2	2	2	2	2	2	2	2
	Standard speed	789	789	715	715	794	794	629	629	629	629	705	705
Motor	Standard motor size	2	2	3	3	3	3	3	3	3	5	5	5
	Standard Motor speed	1420	1420	1435	1435	1435	1435	1435	1435	1440	1440	1440	1440
Accessories	Fan Pulley	225-1B-25	225-1B-25	250-1B-30	250-1B-30	225-1B-30	225-1B-30	280-1B-30	280-1B-30	250-1B-30	250-1B-30	250-1B-30	250-1B-30
	Motor Pulley	125-1B-24	125-1B-24	125-1B-28	125-1B-28	125-1B-28	125-1B-28	125-1B-28	125-1B-28	125-1B-28	125-1B-28	125-1B-28	125-1B-28
Insulation	Belt	B-48	B-48	B-54	B-54	B-52	B-52	B-44	B-44	B-41	B-41	B-41	B-41
	Belt Qty	1	1	1	1	1	1	1	1	1	1	1	1
Insulation	Type	PE Foam											
	Thermal Conductivity Thickness	0.036 w/m.K 10											
Air Filter	Type	Washable Aluminium Filter											
	Qty - Size (Width x Height x Thickness)	1-10"x22"x1"	1-10"x22"x1"	2-10"x22"x1"	2-10"x22"x1"	2-10"x22"x1"	2-10"x22"x1"	2-10"x22"x1"	2-10"x22"x1"	2-10"x22"x1"	3-16"x25"x1"	3-16"x25"x1"	3-16"x25"x1"
Pipe Connection	Chilled water inlet Qty...Dia	1...1-1/4"	1...1-1/4"	1...1-1/4"	1...1-1/4"	1...1-1/4"	1...1-1/4"	1...1-1/4"	1...1-1/2"	1...1-1/2"	1...1-1/2"	1...1-1/2"	1...1-1/2"
	Chilled water outlet Qty...Dia	1...1-1/4"	1...1-1/4"	1...1-1/4"	1...1-1/4"	1...1-1/4"	1...1-1/4"	1...1-1/4"	1...1-1/2"	1...1-1/2"	1...1-1/2"	1...1-1/2"	1...1-1/2"
Pipe Connection	Chilled water pipe connection type	Male Pipe Thread											
	Condensate drain dia.	3/4"	3/4"	3/4"	3/4"	3/4"	3/4"	3/4"	1"	1"	1"	1"	1"
Pipe Connection	Condensate drain connection type	Female Pipe Thread											
		3/4"	3/4"	3/4"	3/4"	3/4"	3/4"	3/4"	1"	1"	1"	1"	1"

Remark : \*\* Nominal capacity base on air ent 80 Fdb-67 Fwb, Ent/Lvg water temp. 44/54 F, Max Air Flow rate.

# Physical data

Model		Packaged Chilled Water Air Handling Unit 40RBW											
		030-3	030-4	033-3	033-4	036-3	036-4	040-3	040-4	050-3	050-4	060-4	080-4
Nominal Capacity	Cooling Capacity *	337,550	404,340	356,500	427,140	392,970	470,060	428,120	518,000	539,320	640,400	726,460	886,140
	Air Flowrate **	10,400	10,400	11,000	11,000	12,100	12,100	13,000	13,000	15,000	15,000	20,000	25,500
Operating Weight		530	560	540	570	550	580	560	590	900	950	1050	1170
	Coil Arrangement	3/14	4/14	3/14	4/14	3/14	4/14	3/14	4/14	3/14	4/14	4/14	4/14
Cooling Coil	Coil Face Area	21.53	21.53	22.69	22.69	25.02	25.02	26.76	26.76	40.22	40.22	40.22	51.11
	Coil / Fin Material	Cu/Al	Cu/Al	Cu/Al	Cu/Al	Cu/Al	Cu/Al	Cu/Al	Cu/Al	Cu/Al	Cu/Al	Cu/Al	Cu/Al
Fan	No. of circuit	2	2	2	2	2	2	2	2	2	2	2	2
	Fan Size	18"x18"	18"x18"	18"x18"	18"x18"	18"x18"	18"x18"	18"x18"	18"x18"	18"x18"	FDA450-SM2	FDA500-SM2	FDA500-SM2
Motor	Fan Qty	2	2	2	2	2	2	2	2	2	2	2	2
	Standard speed	641	641	641	641	683	683	683	683	630	630	630	720
Accessories	Standard motor size	7.5	7.5	7.5	7.5	7.5	7.5	7.5	7.5	10	10	15	20
	Standard Motor speed	1450	1450	1450	1450	1450	1450	1450	1450	1440	1440	1460	1460
Fan Pulley		280-2B-35	280-2B-35	280-2B-35	280-2B-35	315-2B-35	315-2B-35	315-2B-35	315-2B-35	16-2B-40	16-2B-40	16-2B-40	16-3B-40
	Motor Pulley	125-2B-38	125-2B-38	125-2B-38	125-2B-38	150-2B-38	150-2B-38	150-2B-38	150-2B-38	7-2B-38	7-2B-38	7-2B-38	8-3B-42
Belt		B-72	B-72	B-72	B-72	B-76	B-76	B-76	B-76	B-86	B-86	B-89	B-101
	Belt Qty	2	2	2	2	2	2	2	2	2	2	2	2
Insulation	Type	PE Foam											
	Thermal Conductivity Thickness	0.036 w/m.K 10											
Air Filter	Type	Washable Aluminium Filter											
	Qty - Size (Width x Height x Thickness)	2-16"x20"x2" 6-20"x25"x2"	2-16"x20"x2" 6-20"x25"x2"	2-16"x20"x2" 6-20"x25"x2"	2-16"x20"x2" 6-20"x25"x2"	2-16"x20"x2" 6-20"x25"x2"	2-16"x20"x2" 6-20"x25"x2"	2-16"x20"x2" 6-20"x25"x2"	2-16"x20"x2" 6-20"x25"x2"	2-16"x20"x2" 6-20"x25"x2"	2-16"x20"x2" 1-16"x25"x2" 8-20"x20"x2" 4-20"x25"x2"	2-16"x20"x2" 1-16"x25"x2" 8-20"x20"x2" 4-20"x25"x2"	2-16"x20"x2" 1-16"x25"x2" 8-20"x20"x2" 4-20"x25"x2"
Pipe Connection	Chilled water inlet Qty...Dia	2...1-1/2"	2...1-1/2"	2...1-1/2"	2...1-1/2"	2...1-1/2"	2...1-1/2"	2...1-1/2"	2...1-1/2"	2...1-1/2"	2...2-1/2"	2...2-1/2"	2...2-1/2"
	Chilled water outlet Qty...Dia	2...1-1/2"	2...1-1/2"	2...1-1/2"	2...1-1/2"	2...1-1/2"	2...1-1/2"	2...1-1/2"	2...1-1/2"	2...1-1/2"	2...2-1/2"	2...2-1/2"	2...2-1/2"
Condensate drain dia.	Chilled water pipe connection type	Male Pipe Thread											
	Condensate drain connection type	Female Pipe Thread											

Remark : \*\* Nominal capacity base on air ent 80 Fdb-67 Fwb, Ent/Lyg water temp. 44/54 F, Max Air Flow rate.

# Unit dimensions

## Model : 40RBW012-\*\*V (Vertical Type)

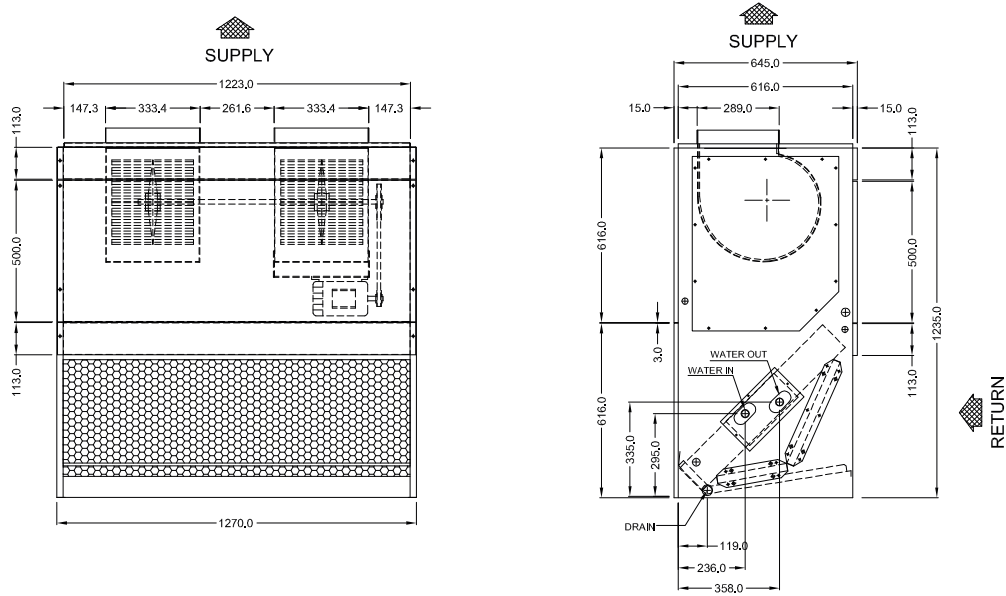

## Model : 40RBW012-\*\*H (Horizontal Type)

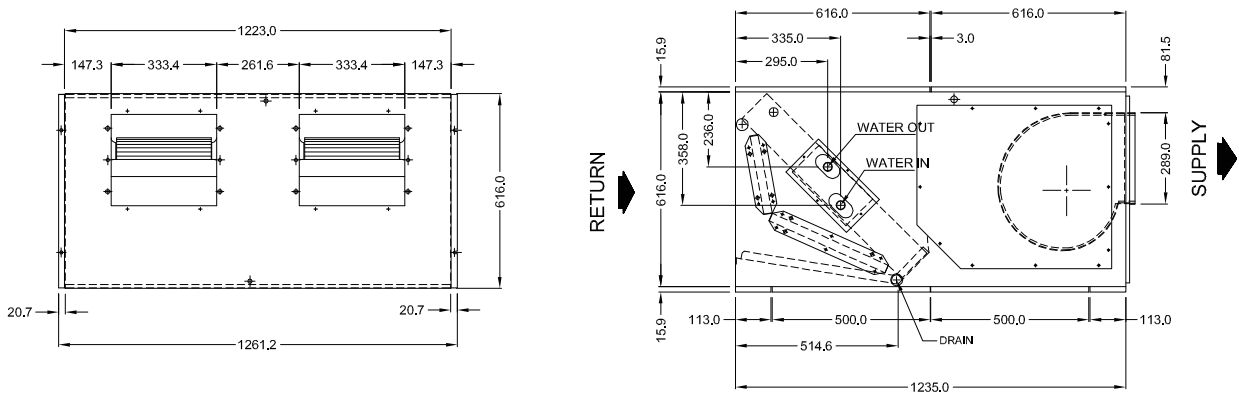

# Unit dimensions

## Model : 40RBW015,018-\*\*V (Vertical Type)

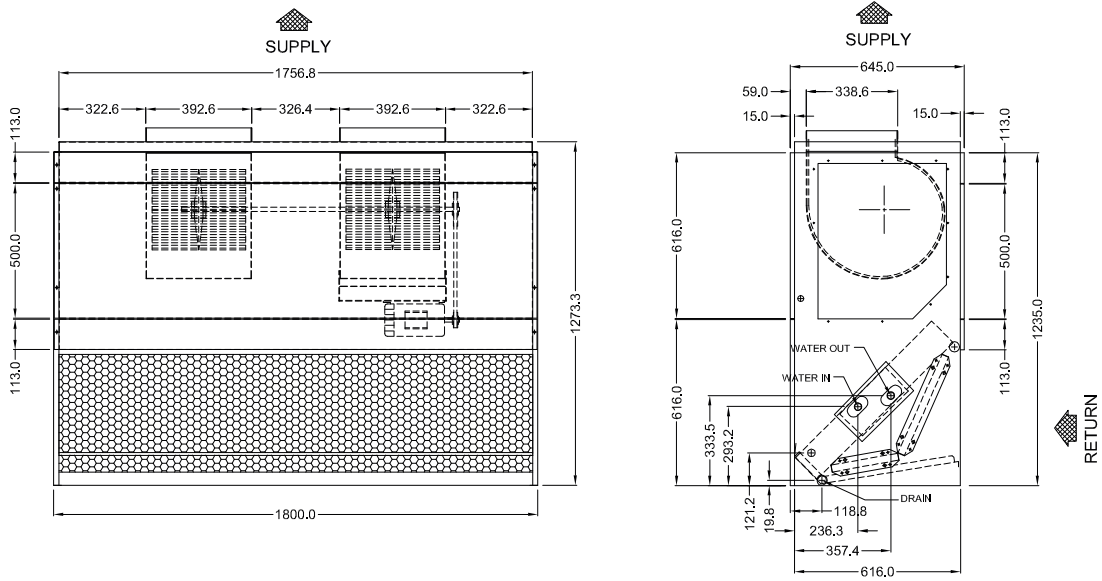

## Model : 40RBW015,018-\*\*H (Horizontal Type)

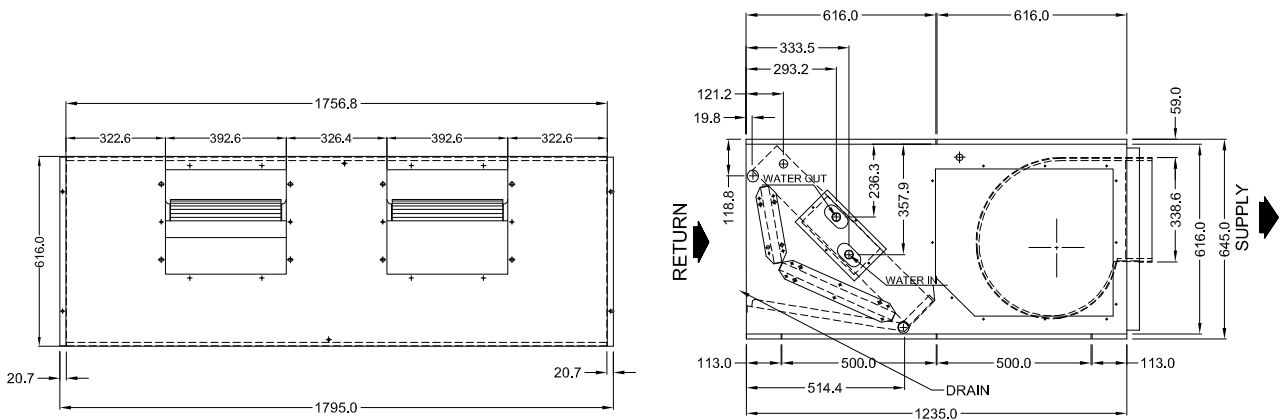

# Unit dimensions

## Model : 40RBW021, 024, 027-\*\*V (Vertical Type)

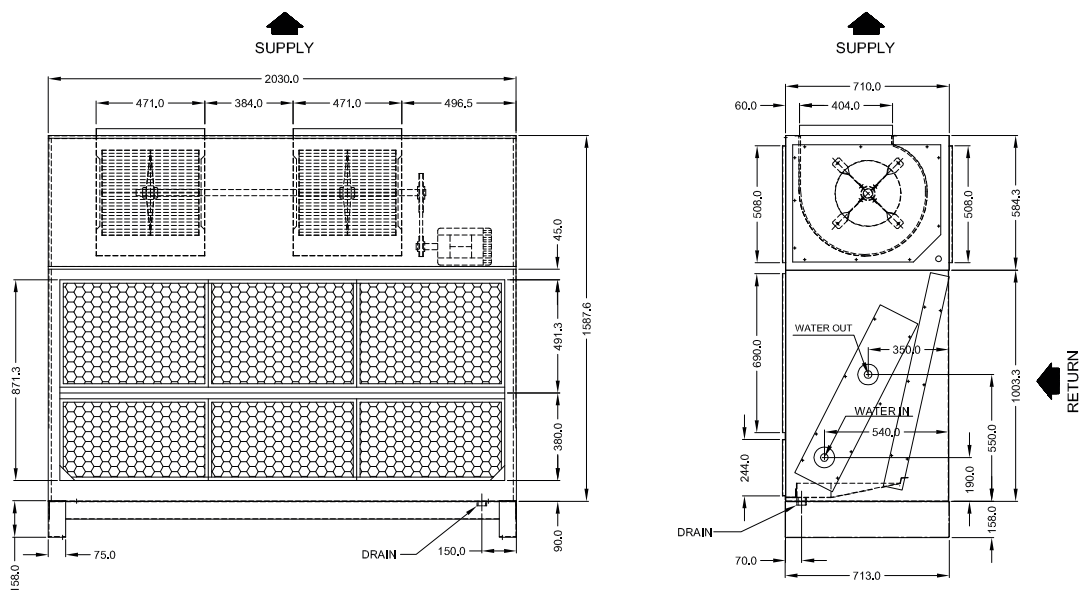

## Model : 40RBW021, 024, 027-\*\*H (Horizontal Type)

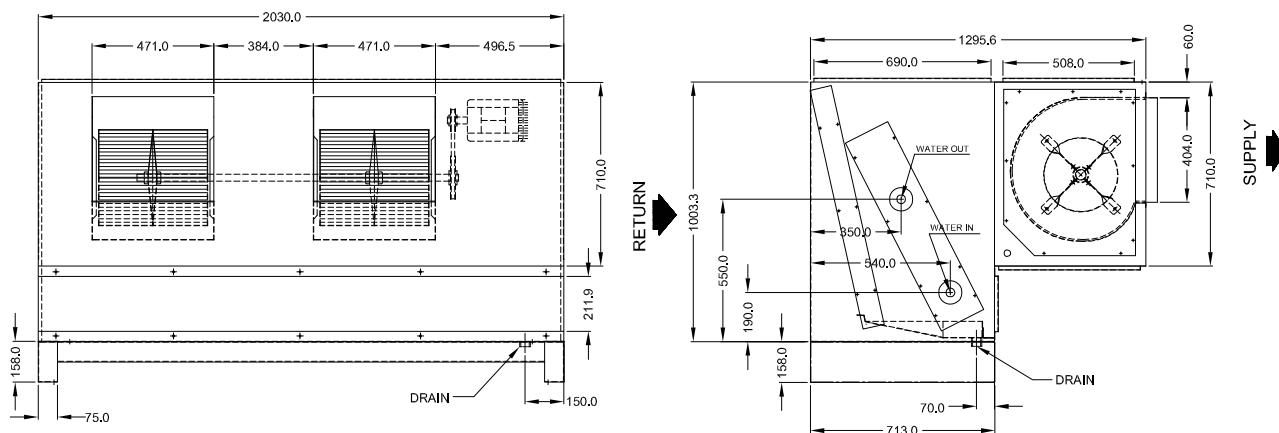

# Unit dimensions

## Model : 40RBW030, 033, 036, 040-\*\*V (Vertical Type)

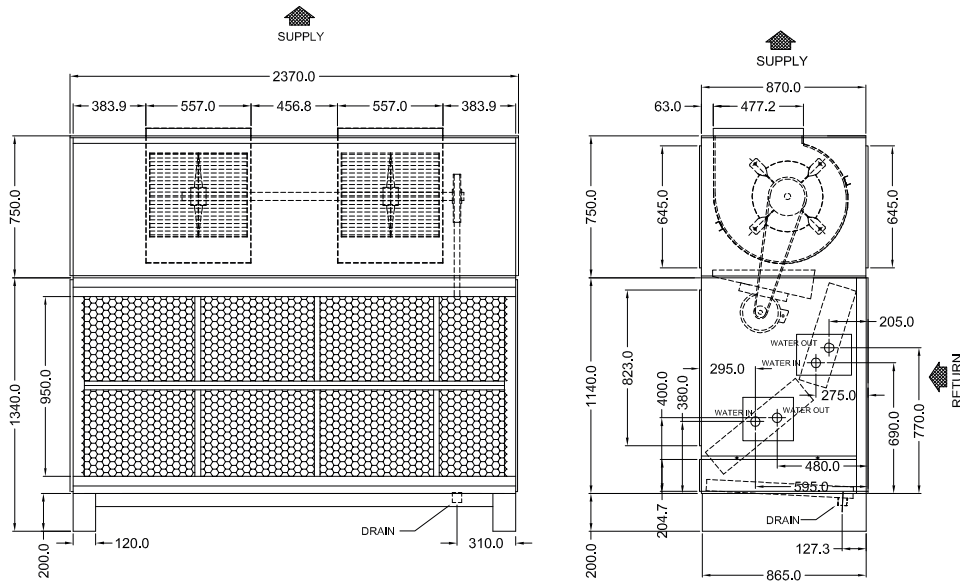

## Model : 40RBW030, 033, 036, 040-\*\*H (Horizontal Type)

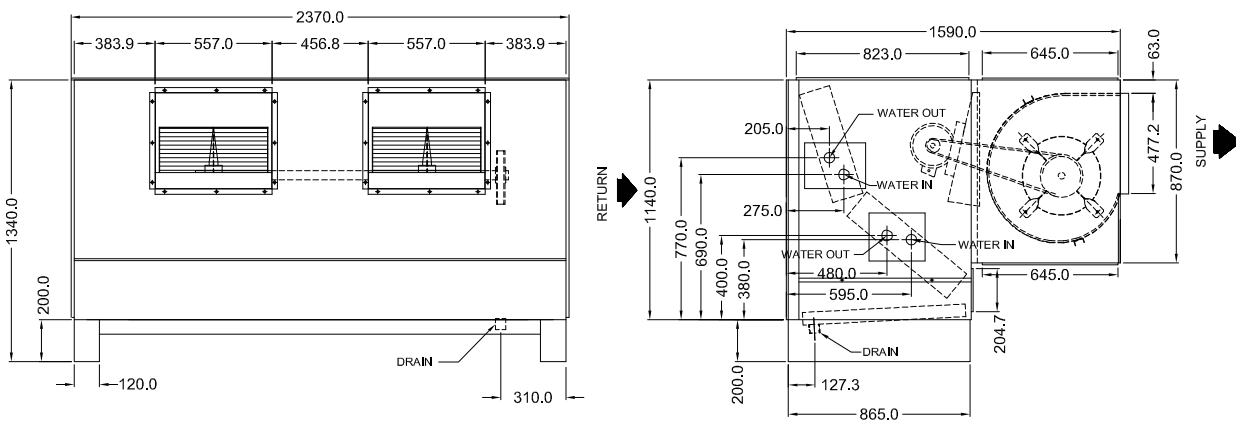



## Unit dimensions

### Model : 40RBW050-\*\*V (Vertical Type)

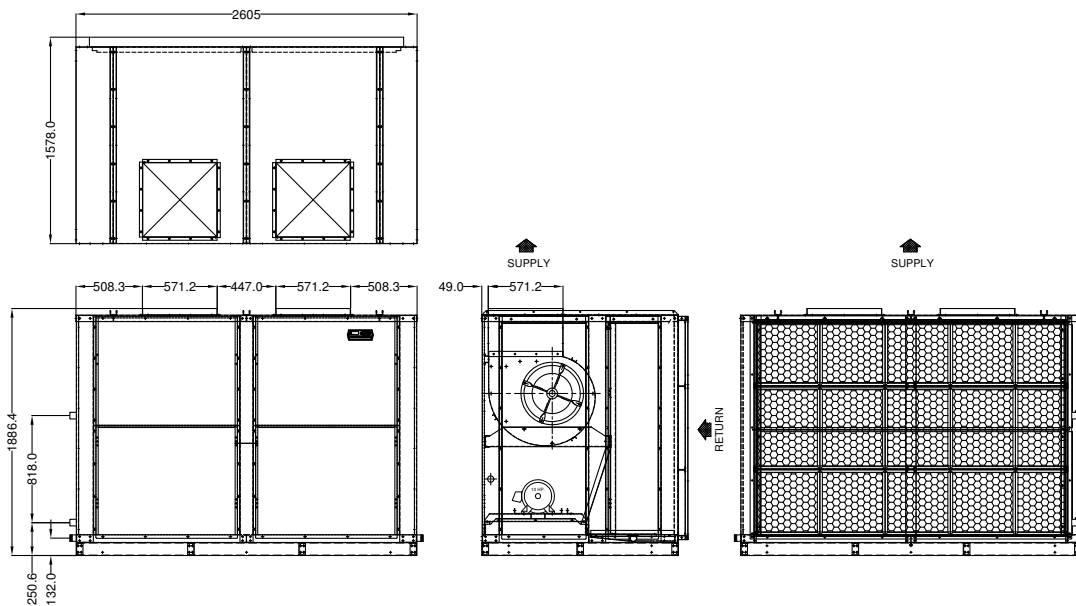

### Model : 40RBW050-\*\*H (Horizontal Type)

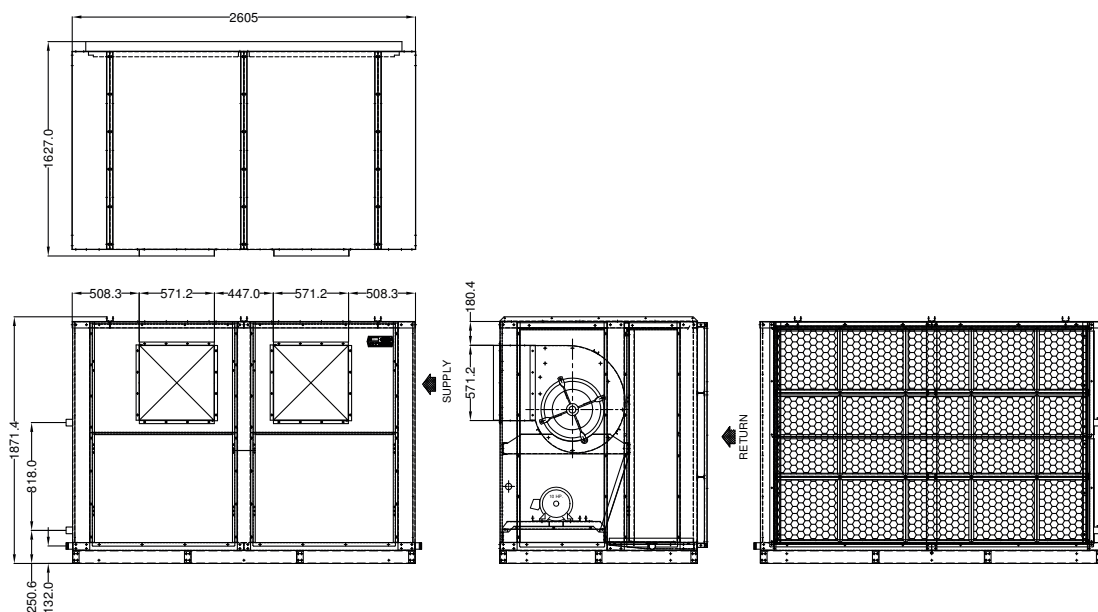

## Unit dimensions

### Model : 40RBW060-\*\*V (Vertical Type)

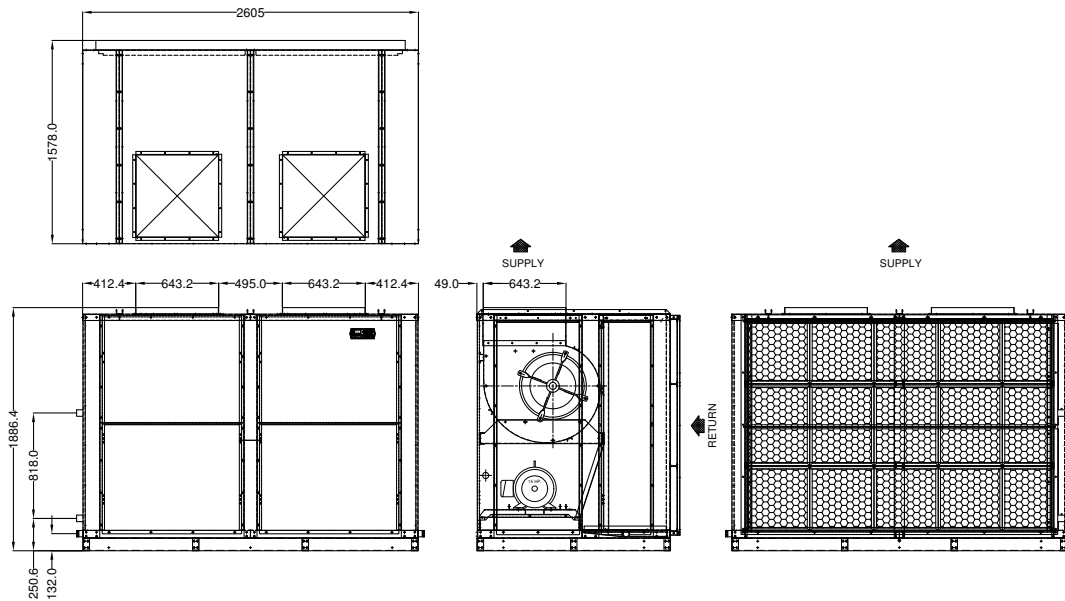

### Model : 40RBW060-\*\*H (Horizontal Type)

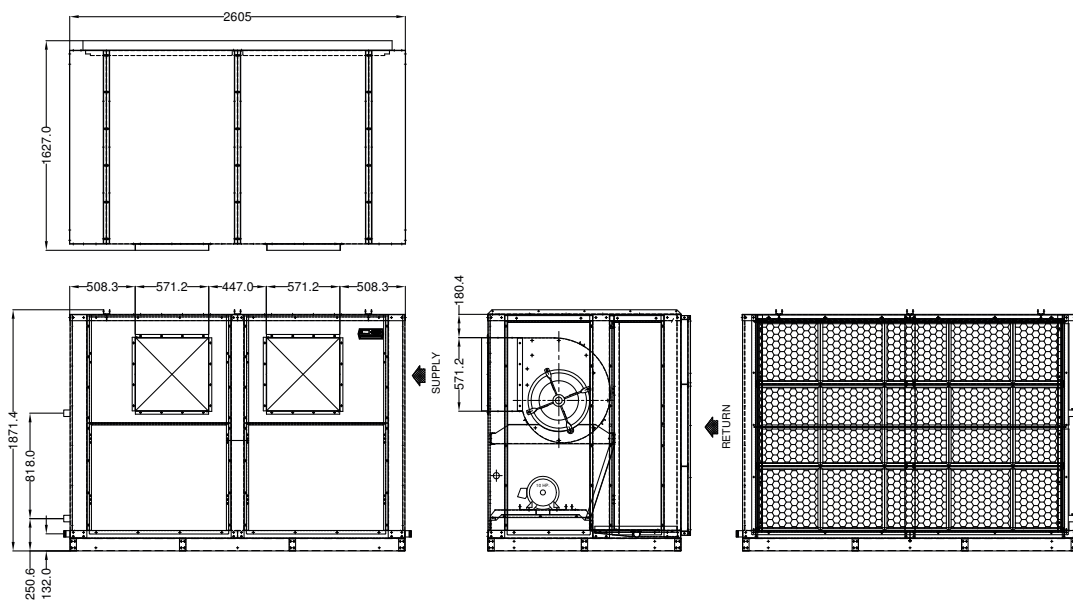

# Unit dimensions

## Model : 40RBW080-\*\*-V (Vertical Type)

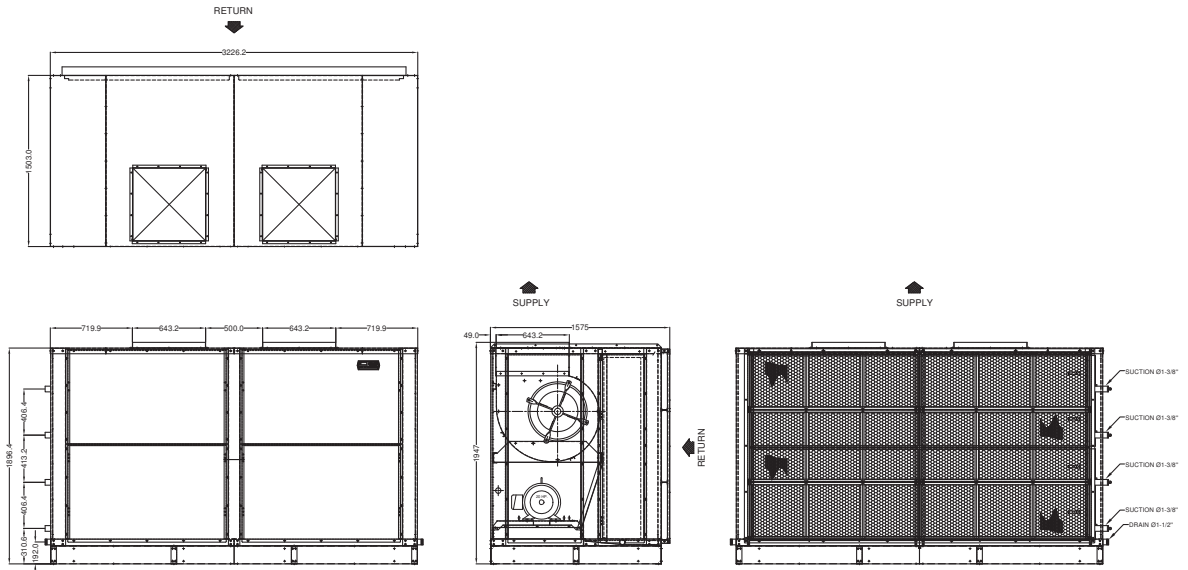

## Model : 40RBW080-\*\*-H (Horizontal Type)

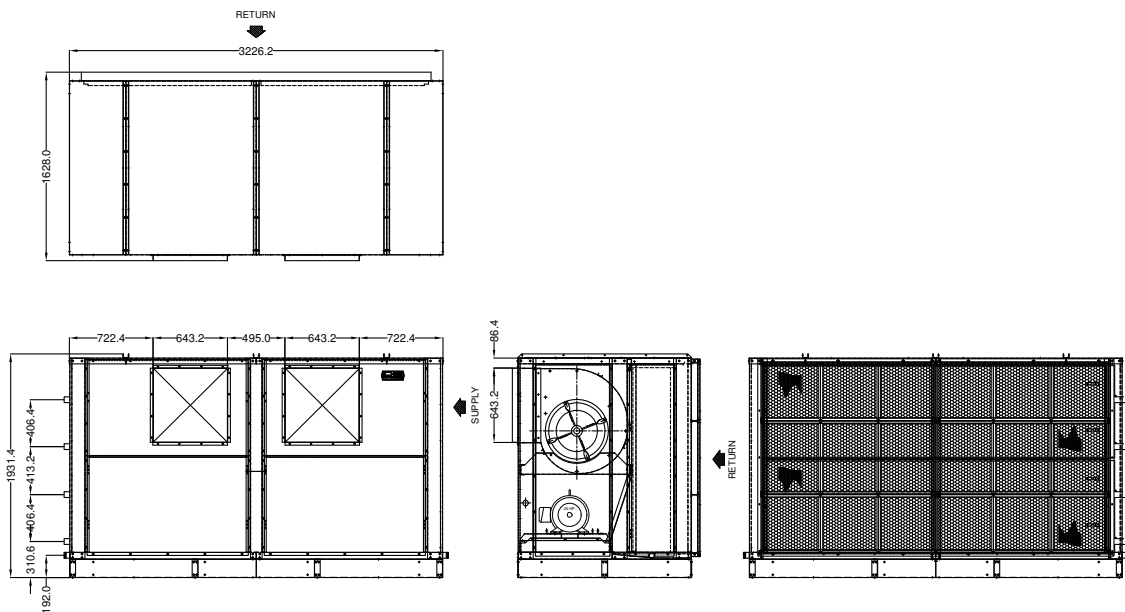

## Coil connection

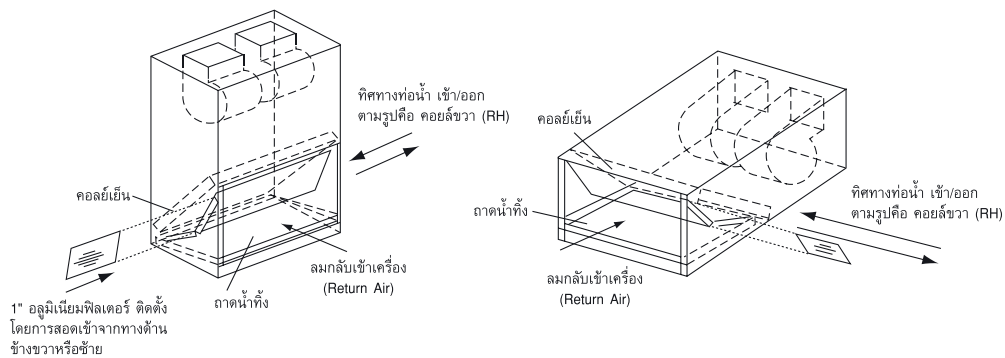

# Fan performance data

Model	Air Flowrate (cfm)	Air Pressure Drop (in.wg)	Total Static Pressure (in.wg)																	
			0.4		0.6		0.8		1.0		1.2		1.4		1.6		1.8		2.0	
			fan speed rpm	power consumption kW	fan speed rpm	power consumption kW	fan speed rpm	power consumption kW	fan speed rpm	power consumption kW	fan speed rpm	power consumption kW	fan speed rpm	power consumption kW	fan speed rpm	power consumption kW	fan speed rpm	power consumption kW	fan speed rpm	power consumption kW
40RBW012-3	3,500	0.25	649	0.48	753	0.60	849	0.71	943	0.83	1,025	0.98	1,111	1.10	1,201	1.27*	1,291	1.49*	1,382	1.7*
40RBW012-4	4,000	0.30	684	0.64	777	0.77	867	0.9	951	1.04	1,037	1.16	1,112	1.32*	1,184	1.49*	1,259	1.62*	1,332	1.7*
40RBW012-4	3,500	0.33	649	0.48	753	0.60	849	0.83	943	0.98	1,025	1.10	1,111	1.10	1,201	1.27*	1,291	1.49*	1,382	1.7*
40RBW015-3	4,000	0.41	684	0.64	777	0.77	867	0.9	951	1.04	1,037	1.16	1,112	1.32*	1,184	1.49*	1,259	1.62*	-	-
40RBW015-3	4,500	0.25	532	0.54	639	0.70	729	0.87	819	1.06	1,046	1.43	1,027	1.59	-	-	-	-	-	-
40RBW015-4	5,100	0.31	546	0.68	644	0.86	737	1.05	819	1.25	893	1.45	979	1.69	-	-	-	-	-	-
40RBW015-4	4,500	0.34	532	0.54	639	0.70	729	0.87	819	1.06	1,046	1.43	1,027	1.59	-	-	-	-	-	-
40RBW015-4	5,100	0.42	546	0.68	644	0.86	737	1.05	819	1.25	893	1.45	979	1.69	-	-	-	-	-	-
40RBW018-3	5,500	0.27	561	0.80	651	0.98	740	1.18	822	1.39	893	1.60	965	1.82*	1,044	2.08*	1,131	2.39*	1,217	2.74*
40RBW018-3	6,000	0.30	583	0.97	662	1.15	746	1.37	826	1.59	900	1.82*	965	2.05*	1,030	2.28*	1,100	2.55*	1,176	2.85*
40RBW018-4	5,500	0.35	561	0.80	651	0.98	740	1.18	822	1.39	893	1.60	965	1.82*	1,044	2.08*	1,131	2.39*	1,217	2.74*
40RBW018-4	6,000	0.41	583	0.97	662	1.15	746	1.37	826	1.59	900	1.82*	965	2.05*	1,030	2.28*	1,100	2.55*	1,176	2.85*
40RBW021-3	6,500	0.28	460	0.76	554	0.89	633	1.21	708	1.47	777	1.74	845	2.02*	911	2.34*	978	2.69*	1,045	3.07*
40RBW021-3	7,050	0.31	481	0.83	556	1.13	636	1.38	708	1.62	776	1.91*	839	2.21*	901	2.50*	963	2.83*	1,025	3.20*
40RBW021-4	6,500	0.36	460	0.76	554	0.89	633	1.21	708	1.47	777	1.74	845	2.02*	911	2.34*	978	2.69*	1,045	3.07*
40RBW021-4	7,050	0.41	481	0.83	556	1.13	636	1.38	708	1.62	776	1.91*	839	2.21*	901	2.50*	963	2.83*	1,025	3.20*
40RBW024-3	7,500	0.27	-	-	558	1.26	639	1.53	709	1.78	776	2.05	838	2.36	897	2.68*	956	3.00*	-	-
40RBW024-3	8,000	0.30	-	-	584	1.41	641	1.69	712	1.98	776	2.24	838	2.54*	896	2.88*	951	3.22*	-	-
40RBW024-4	7,500	0.37	-	-	558	1.26	639	1.53	709	1.78	776	2.05	838	2.36	897	2.68*	956	3.00*	-	-
40RBW024-4	8,000	0.40	-	-	584	1.41	641	1.69	712	1.98	776	2.24	838	2.54*	896	2.88*	951	3.22*	-	-
40RBW027-3	8,500	0.28	-	-	583	1.63	644	1.88	715	2.18	778	2.47	838	2.76	896	3.08	-	-	-	-
40RBW027-3	9,000	0.30	-	-	617	2.39	717	2.59	782	3.01	839	3.01	896	3.22*	-	-	-	-	-	-
40RBW027-4	8,500	0.37	-	-	583	1.63	644	1.88	715	2.18	778	2.47	838	2.76	896	3.08	-	-	-	-
40RBW027-4	9,000	0.41	-	-	617	2.39	717	2.59	782	3.01	839	3.01	896	3.22*	-	-	-	-	-	-
40RBW030-3	9,500	0.26	396	1.13	465	1.42	531	1.75	589	2.09	647	2.49	716	2.97	787	3.57	853	4.23	885	4.97*
40RBW030-3	10,450	0.30	413	1.40	473	1.69	534	2.02	593	2.39	645	2.76	697	3.19	757	3.68	822	4.28	885	4.97*
40RBW030-4	9,500	0.35	396	1.13	465	1.42	531	1.75	589	2.09	647	2.49	716	2.97	787	3.57	853	4.23	885	4.97*
40RBW030-4	10,450	0.40	413	1.40	473	1.69	534	2.02	593	2.39	645	2.76	697	3.19	757	3.68	822	4.28	885	4.97*
40RBW033-3	10,500	0.28	414	1.42	473	1.71	535	2.04	593	2.40	645	2.78	696	3.20	755	3.69	821	4.28	884	4.98*
40RBW033-3	11,050	0.31	426	1.60	477	1.87	538	2.22	595	2.60	648	2.98	696	3.39	746	3.85	803	4.39	866	5.02*
40RBW033-4	10,500	0.37	414	1.42	473	1.71	535	2.04	593	2.40	645	2.78	696	3.20	755	3.69	821	4.28	884	4.98*
40RBW033-4	11,050	0.41	426	1.60	477	1.87	538	2.22	595	2.60	648	2.98	696	3.39	746	3.85	803	4.39	866	5.02*
40RBW036-3	11,500	0.28	436	1.76	483	2.02	541	2.39	597	2.76	650	3.16	697	3.57	744	4.02	794	4.52*	851	5.1*
40RBW036-3	12,150	0.30	451	2.02	493	2.28	546	2.64	600	3.02	652	3.43	700	3.85	745	4.29	789	4.77*	836	5.30*
40RBW036-4	11,500	0.37	436	1.76	483	2.02	541	2.39	597	2.76	650	3.16	697	3.57	744	4.02	794	4.52*	851	5.1*
40RBW036-4	12,150	0.40	451	2.02	493	2.28	546	2.64	600	3.02	652	3.43	700	3.85	745	4.29	789	4.77*	836	5.30*
40RBW040-3	12,500	0.29	459	2.16	500	2.44	549	2.77	602	3.17	654	3.58	702	4.02	746	4.46	789	4.77*	833	5.45*
40RBW040-3	13,000	0.30	470	2.39	510	2.67	554	2.98	606	3.41	655	3.81	704	4.26	749	4.71*	791	5.18*	831	5.68*
40RBW040-4	12,500	0.38	459	2.16	500	2.44	549	2.77	602	3.17	654	3.58	702	4.02	746	4.46	789	4.77*	833	5.45*
40RBW040-4	13,000	0.40	470	2.39	510	2.67	554	2.98	606	3.41	655	3.81	704	4.26	749	4.71*	791	5.18*	831	5.68*
40RBW050-3	12,700	0.16	410	1.84	469	2.23	523	2.63	575	3.07	625	3.52	673	3.99	721	4.51	768	5.08	816	5.68
40RBW050-3	15,000	0.21	442	2.67	495	3.12	544	3.59	592	4.06	636	4.54	680	5.07	723	5.6	764	6.15*	805	6.72*
40RBW050-4	12,700	0.21	410	1.84	469	2.23	523	2.63	575	3.07	625	3.52	673	3.99	721	4.51	768	5.08	816	5.68
40RBW050-4	15,000	0.28	442	2.67	495	3.12	544	3.59	592	4.06	636	4.54	680	5.07	723	5.6	764	6.15*	805	6.72*
40RBW060-4	15,200	0.27	384	2.11	441	2.59	495	3.1	545	3.65	495	3.1	545	3.65	495	3.1	545	3.65	495	3.1
40RBW060-4	20,000	0.41	438	3.94	484	4.52	529	5.15	572	5.78	613	6.43	654	7.12	693	7.83	730	8.56	-	-
40RBW060-4	20,500	0.28	444	4.18	489	4.78	534	5.41	576	6.06	616	6.72	656	7.42	695	8.14	732	8.87	-	-
25500	0.38	512	7.26	549	7.98	585	8.72	621	9.47	657	10.26	692	11.07	725	11.87	-	-	-	-	-

Remark: \* Motor Size need to be changed.

# Performance data

## Ent/Lvg Water Temp 44/54°F Capacity

MODEL	Ent. Air Temp (Fdb/Fwb)		76 / 63			78 / 65			80 / 67			82 / 69		
	Air Fbwrate (cfm)	Pressure Drop	Total Capacity (btu/h)	Sensible Capacity (btu/h)	Water Flowrate (gpm)	Total Capacity (btu/h)	Sensible Capacity (btu/h)	Water Flowrate (gpm)	Total Capacity (btu/h)	Sensible Capacity (btu/h)	Water Flowrate (gpm)	Total Capacity (btu/h)	Sensible Capacity (btu/h)	Water Flowrate (gpm)
40RBW012-3	3,500	0.25	88,900	77,850	17.8	104,500	81,880	20.9	119,190	85,260	23.8	134,200	88,440	26.8
	4,000	0.30	96,850	86,360	19.4	114,100	90,700	22.8	129,380	93,970	25.9	145,350	97,100	29.1
40RBW012-4	3,500	0.33	108,130	88,930	21.6	126,420	94,380	25.3	144,130	99,140	28.8	161,320	103,320	32.3
	4,000	0.41	120,220	100,210	24.0	138,980	105,560	27.8	158,360	110,720	31.7	178,100	115,530	35.6
40RBW015-3	4,500	0.25	113,570	99,730	22.7	132,460	104,490	26.5	150,500	108,530	30.1	169,620	112,520	33.9
	5,100	0.31	123,930	110,240	24.8	143,970	115,060	28.8	163,430	119,220	32.7	184,670	123,500	36.9
40RBW015-4	4,500	0.34	130,260	110,650	26.1	153,300	117,530	30.7	176,800	124,020	35.4	199,730	129,730	39.9
	5,100	0.42	141,560	122,940	28.3	166,840	130,390	33.4	193,620	137,820	38.7	216,820	143,300	43.4
40RBW018-3	5,500	0.27	136,270	120,600	27.3	160,530	126,860	32.1	183,130	131,980	36.6	206,460	136,810	41.3
	6,000	0.30	143,580	128,780	28.7	170,340	135,700	34.1	193,060	140,530	38.6	216,760	145,080	43.4
40RBW018-4	5,500	0.35	159,020	135,150	31.8	187,050	143,500	37.4	216,090	151,570	43.2	243,530	158,300	48.7
	6,000	0.41	168,330	145,360	33.7	198,270	154,210	39.7	229,870	162,980	46.0	257,350	169,440	51.5
40RBW021-3	6,500	0.28	163,630	143,520	32.7	190,640	150,240	38.1	216,400	155,900	43.3	243,980	161,610	48.8
	7,050	0.31	173,280	153,170	34.7	201,030	159,740	40.2	228,110	165,560	45.6	257,540	171,560	51.5
40RBW021-4	6,500	0.36	194,420	146,270	38.9	226,240	171,690	45.2	258,130	180,240	51.6	289,530	187,780	57.9
	7,050	0.41	206,260	174,280	41.3	238,040	183,250	47.6	271,480	192,060	54.3	305,530	200,360	61.1
40RBW024-3	7,500	0.27	187,870	165,080	37.6	219,700	173,090	43.9	249,500	179,630	49.9	280,780	185,980	56.2
	8,000	0.30	197,050	174,010	39.4	229,290	181,770	45.9	260,040	188,390	52.0	292,840	194,920	58.6
40RBW024-4	7,500	0.37	218,890	185,170	43.8	256,960	196,450	51.4	295,530	207,040	59.1	331,550	215,660	66.3
	8,000	0.40	229,050	195,680	45.8	269,520	207,700	53.9	308,260	218,020	61.7	345,300	226,790	69.1
40RBW027-3	8,500	0.28	202,930	182,970	40.6	239,480	192,360	47.9	272,190	199,490	54.4	305,650	205,990	61.1
	9,000	0.30	211,560	191,670	42.3	248,760	200,940	49.7	282,310	208,040	56.5	316,750	214,550	63.4
40RBW027-4	8,500	0.37	243,690	208,040	48.7	285,930	220,550	57.2	329,310	232,370	65.9	369,490	242,020	73.9
	9,000	0.41	253,790	218,560	50.8	298,410	231,720	59.7	341,930	243,310	68.4	383,120	253,060	76.6
40RBW030-3	9,500	0.26	238,160	209,550	47.6	277,050	219,170	55.4	314,360	227,330	62.9	355,040	235,860	71.0
	10,450	0.30	253,740	225,810	50.7	294,860	235,700	59.0	335,000	244,330	67.0	378,330	259,446	75.4
40RBW030-4	9,500	0.35	285,930	238,170	57.2	334,210	252,370	66.8	381,680	265,220	76.3	427,430	276,180	85.5
	10,450	0.40	309,560	259,980	61.9	357,750	273,610	71.6	407,740	286,840	81.5	458,080	299,060	91.6
40RBW033-3	10,500	0.28	258,790	229,150	51.8	300,910	239,350	60.2	341,500	248,210	68.3	386,400	257,540	77.3
	11,050	0.31	267,660	238,470	53.5	311,130	248,930	62.2	353,840	258,150	70.8	438,510	300,776	87.5
40RBW033-4	10,500	0.37	313,180	262,090	62.6	364,440	276,930	72.9	415,590	290,600	83.1	465,950	302,630	93.2
	11,050	0.41	327,170	274,840	65.4	377,910	289,160	75.6	430,730	303,140	86.1	483,980	316,080	96.8
40RBW036-3	11,500	0.28	284,550	251,530	56.9	330,840	262,780	66.2	375,410	272,500	75.1	424,760	282,820	84.9
	12,150	0.30	295,030	262,540	59.0	342,960	274,090	68.6	390,010	284,270	78.0	484,210	331,791	96.6
40RBW036-4	11,500	0.37	343,400	287,210	68.7	399,910	303,610	80.0	456,100	318,660	91.2	511,230	331,820	102.2
	12,150	0.40	359,910	302,270	72.0	415,890	318,100	83.2	474,010	333,480	94.8	532,540	347,690	106.5
40RBW040-3	12,500	0.29	312,100	274,260	62.4	362,270	286,390	72.4	411,010	296,930	82.2	465,230	308,340	93.0
	13,000	0.30	320,290	282,780	64.1	371,720	295,000	74.3	422,360	306,020	84.5	512,870	349,228	102.3
40RBW040-4	12,500	0.38	373,670	312,350	74.7	434,240	329,840	86.8	495,030	346,070	99.0	555,280	360,510	111.1
	13,000	0.40	386,560	324,010	77.3	446,520	340,970	89.3	508,870	357,500	101.8	571,780	372,710	114.4
40RBW050-3	12,700	0.16	359,780	299,740	71.8	416,040	318,460	83.0	480,320	338,500	95.8	553,240	359,820	110.3
	15,000	0.21	404,760	342,440	80.7	468,060	363,600	93.4	539,320	385,880	107.6	622,040	409,880	124.1
40RBW050-4	12,700	0.21	424,680	335,600	84.7	491,020	357,080	97.9	564,940	380,120	112.7	645,160	403,960	128.7
	15,000	0.28	481,360	385,880	96.0	557,000	410,360	111.1	640,400	436,220	127.7	732,460	463,380	146.1
40RBW060-4	15,200	0.27	447,200	371,440	89.2	516,520	394,540	103.0	597,040	419,440	119.1	681,460	444,360	135.9
	20,000	0.41	545,460	464,640	108.8	627,460	492,840	125.2	726,460	523,320	144.9	829,180	553,420	165.4
40RBW080-4	20,500	0.28	567,700	482,500	113.2	658,560	513,200	131.4	760,600	544,860	151.7	882,340	581,080	176.0
	25,500	0.38	663,160	575,060	132.3	766,500	611,320	152.9	886,140	648,400	176.7	1,028,700	690,920	205.2

# Performance data

## Ent/Lvg Water Temp 45/55°F Capacity

MODEL	Ent. Air Temp (Fdb/Fwb)		76 / 63			78 / 65			80 / 67			82 / 69		
	Air Fbwrate (cfm)	Pressure Drop	Total Capacity (btu/h)	Sensible Capacity (btu/h)	Water Flowrate (gpm)	Total Capacity (btu/h)	Sensible Capacity (btu/h)	Water Flowrate (gpm)	Total Capacity (btu/h)	Sensible Capacity (btu/h)	Water Flowrate (gpm)	Total Capacity (btu/h)	Sensible Capacity (btu/h)	Water Flowrate (gpm)
40RBW012-3	3,500	0.25	82,770	75,540	16.6	98,810	79,850	19.8	113,520	83,280	22.7	128,070	86,310	25.6
	4,000	0.30	90,050	83,900	18.0	108,450	88,770	21.7	123,470	91,980	24.7	138,630	94,860	27.7
40RBW012-4	3,500	0.33	101,650	86,230	20.3	119,860	91,690	24.0	137,320	96,420	27.5	154,230	100,490	30.8
	4,000	0.41	113,010	97,260	22.6	131,900	102,720	26.4	150,870	107,720	30.2	169,820	112,340	34.0
40RBW015-3	4,500	0.25	105,740	96,780	21.1	125,730	102,080	25.1	143,590	106,120	28.7	161,610	109,740	32.3
	5,100	0.31	116,080	107,450	23.2	136,780	112,570	27.4	155,900	116,670	31.2	175,620	120,490	35.1
40RBW015-4	4,500	0.34	122,270	107,450	24.5	144,690	114,080	28.9	167,700	120,380	33.5	190,570	126,210	38.1
	5,100	0.42	132,520	119,320	26.5	157,830	126,790	31.6	183,080	133,690	36.6	207,250	139,690	41.4
40RBW018-3	5,500	0.27	126,430	116,980	25.3	151,700	123,670	30.3	174,660	129,040	34.9	196,900	133,550	39.4
	6,000	0.30	133,460	125,130	26.7	160,900	132,410	32.2	184,280	137,550	36.9	206,750	141,780	41.3
40RBW018-4	5,500	0.35	149,210	131,230	29.8	176,750	139,380	35.3	204,800	147,050	41.0	232,630	154,140	46.5
	6,000	0.41	157,570	141,050	31.5	187,560	149,920	37.5	217,780	158,240	43.6	246,010	165,140	49.2
40RBW021-3	6,500	0.28	152,230	138,240	30.4	181,000	146,790	36.2	206,540	152,490	41.3	232,380	157,630	46.5
	7,050	0.31	161,760	149,020	32.4	191,030	156,320	38.2	217,630	162,020	43.5	244,980	167,310	49.0
40RBW021-4	6,500	0.36	182,530	157,590	36.5	214,490	166,990	42.9	245,970	175,380	49.2	276,390	182,720	55.3
	7,050	0.41	193,840	169,250	38.8	226,360	178,580	45.3	258,560	186,960	51.7	291,240	194,870	58.2
40RBW024-3	7,500	0.27	174,770	160,180	35.0	208,700	169,170	41.7	238,060	175,690	47.6	267,850	181,590	53.6
	8,000	0.30	183,090	168,940	36.6	217,920	177,850	43.6	248,150	184,340	49.6	278,820	190,180	55.8
40RBW024-4	7,500	0.37	205,090	179,600	41.0	242,730	190,750	48.5	281,460	201,410	56.3	316,660	209,960	63.3
	8,000	0.40	214,550	189,870	42.9	254,530	201,700	50.9	293,760	212,280	58.8	330,020	220,950	66.0
40RBW027-3	8,500	0.28	188,530	177,740	37.7	227,410	188,140	45.5	259,520	195,150	51.9	291,480	201,250	58.3
	9,000	0.30	196,380	186,230	39.3	236,360	196,760	47.3	269,340	203,650	53.9	301,930	209,630	60.4
40RBW027-4	8,500	0.37	228,250	201,860	45.6	270,450	214,310	54.1	313,620	226,100	62.7	352,890	235,580	70.6
	9,000	0.41	237,540	212,060	47.5	282,060	225,180	56.4	325,790	237,010	65.2	366,120	246,670	73.2
40RBW030-3	9,500	0.26	221,600	203,350	44.3	262,910	214,110	52.6	300,000	222,380	60.0	337,880	229,960	67.6
	10,450	0.30	238,230	220,310	47.6	280,100	230,590	56.0	319,330	239,020	63.9	360,210	247,020	72.0
40RBW030-4	9,500	0.35	268,650	231,080	53.7	316,610	245,320	63.3	363,450	257,920	72.7	408,540	268,790	81.7
	10,450	0.40	290,050	251,980	58.0	339,910	266,470	68.0	388,420	279,110	77.7	436,780	290,570	87.4
40RBW033-3	10,500	0.28	242,370	223,080	48.5	285,810	234,110	57.2	325,790	242,810	65.2	367,510	251,000	73.5
	11,050	0.31	251,290	232,660	50.3	295,540	243,530	59.1	337,010	252,420	67.4	380,520	261,000	76.1
40RBW033-4	10,500	0.37	293,870	254,170	58.8	345,750	269,450	69.1	396,020	282,760	79.2	444,990	294,590	89.0
	11,050	0.41	306,520	266,370	61.3	359,100	281,640	71.8	410,320	294,970	82.1	461,460	307,280	92.3
40RBW036-3	11,500	0.28	265,980	244,790	53.2	314,210	256,930	62.8	358,160	266,590	71.6	404,030	275,730	80.8
	12,150	0.30	277,050	256,170	55.4	325,790	268,130	65.2	371,480	277,970	74.3	419,470	287,430	83.9
40RBW036-4	11,500	0.37	322,280	278,550	64.5	379,320	295,370	75.9	434,630	310,060	86.9	488,350	323,020	97.7
	12,150	0.40	337,210	292,960	67.4	395,160	309,800	79.0	451,550	324,490	90.3	507,780	338,030	101.6
40RBW040-3	12,500	0.29	292,490	276,010	58.5	344,140	279,960	68.8	392,150	290,490	78.4	442,570	300,630	88.5
	13,000	0.30	300,820	275,730	60.2	353,170	288,640	70.6	402,520	299,250	80.5	454,600	309,550	90.9
40RBW040-4	12,500	0.38	350,540	302,860	70.1	411,980	320,930	82.4	471,690	336,730	94.3	530,070	350,830	106.0
	13,000	0.40	362,190	314,020	72.4	424,170	332,030	84.8	484,780	347,860	97.0	545,190	362,440	109.0
40RBW050-3	12,700	0.16	337,060	289,420	7.6	392,820	308,080	10.0	453,360	327,180	90.5	525,660	348,460	104.9
	15,000	0.20	379,500	330,800	9.4	441,900	351,860	12.2	509,340	373,280	101.6	590,520	397,040	117.8
40RBW050-4	12,700	0.21	398,320	323,800	7.1	464,420	345,260	9.3	535,080	367,240	106.8	615,600	391,280	122.8
	15,000	0.28	451,200	372,420	8.9	526,480	396,860	11.6	605,920	421,500	120.9	698,240	448,860	139.3
40RBW060-4	15,200	0.27	420,500	358,980	4.5	485,320	381,100	5.7	565,060	405,800	112.7	648,360	430,420	129.4
	20,000	0.41	512,760	449,160	6.3	591,940	476,700	8.1	686,740	506,540	137.0	789,200	536,680	157.5
40RBW080-4	20,500	0.28	534,780	466,700	2.2	618,520	495,900	2.8	719,940	527,500	143.6	835,580	562,140	166.7
	25,500	0.38	624,400	556,340	2.9	716,920	589,500	3.7	838,020	628,000	167.2	973,100	668,700	194.1
40RBW050-3	12,700	0.16	337,060	289,420	67.3	392,820	308,080	78.4	453,360	327,180	90.5	525,660	348,460	104.9
	15,000	0.20	379,500	330,800	75.7	441,900	351,860	88.2	509,340	373,280	101.6	590,520	397,040	117.8
40RBW050-4	12,700	0.21	398,320	323,800	79.5	464,420	345,260	92.7	535,080	367,240	106.8	615,600	391,280	122.8
	15,000	0.28	451,200	372,420	90.0	526,480	396,860	105.0	605,920	421,500	120.9	698,240	448,860	139.3
40RBW060-4	15,200	0.27	420,500	358,980	83.9	485,320	381,100	96.8	565,060	405,800	112.7	648,360	430,420	129.4
	20,000	0.41	512,760	449,160	102.3	591,940	476,700	118.1	686,740	506,540	137.0	789,200	536,680	157.5
40RBW080-4	20,500	0.28	534,780	466,700	106.7	618,520	495,900	123.4	719,940	527,500	143.6	835,580	562,140	166.7
	25,500	0.38	624,400	556,340	124.6	716,920	589,500	143.0	838,020	628,000	167.2	973,100	668,700	194.1

บริษัท แครีเยอร์ (ประเทศไทย) จำกัด  
1858/63-74 ชั้น 14, 15  
ถ.เทพรัตน กม. 4.5 แขวงบางนาใต้  
เขตบางนา กรุงเทพฯ 10260  
โทร. 0-2090-9999 แฟกซ์: 0-2751-4778

Carrier (Thailand) Ltd.  
1858/63-74, 14<sup>th</sup>, 15<sup>th</sup> Floor,  
Debaratna Road, Km.4.5, Bangna Tai,  
Bangna Bangkok 10260 Thailand  
Tel. 0-2090-9999 Fax: 0-2751-4778

บริษัทฯ ขอสงวนสิทธิ์ที่จะเปลี่ยนแปลงรายละเอียดข้างต้น โดยไม่ต้องแจ้งให้ทราบล่วงหน้า  
Carrier reserves the right to make changes in specifications without prior notice.



YOUR CARRIER MAN :